



SERIES 100 FILTER COALESCING

The Series 100 coalescing filter is designed to meet the needs of light and medium duty gas engines. A high strength aluminum housing and unique multiple layer filter element that combines both particulate and coalescing filtration make the Series 100 filter the ideal choice for the most demanding applications.

High Pressure Filtration – Gaseous fueled engines need protection from solid particulate matter and oil aerosols, both of which can damage fuel injectors, carburetors, and regulators. By combining both forms of filtration in one element, the Series 100 filter provides highly efficient and cost effective fuel system protection.

Filter Element – A custom three-layer element has been designed for the Pensare family of filters. The first layer of the filter is a 10-micron cellulose pre-filter that traps any particulate matter before it can reach the coalescing element. The structure of the filter traps dirt as the gas moves through the entire depth, not just on the surface. The pre-filter protects and greatly extends the life of the coalescing element.

The second layer of the filter is a borosilicate fiber/microglass paper coalescing element. It removes more than 99.9 percent of the aerosols in the 0.3-micron range (higher efficiency filters, to 99.999 percent, are available by custom order).

The third layer of the filter is made of cellulose fiber that provides a drain layer for aerosols that have coalesced into oil droplets. The oil droplets migrate to the bottom of the filter and drop into the sump.

Filter Housing – The filter housing is made of high strength 7075 and 6061 aluminum alloy and is rated for a maximum operating pressure of 3600 psig. The filter housing is clear anodized for corrosion resistance and is designed for undercarriage applications that are subject to dirt and debris encountered by working vehicles. A 2.5-inch clearance is required beneath the filter housing for servicing of the element.

The Series 100 filter will provide complete filtration and is suitable for use in the most demanding environments, typical of the rigors of fleet vehicles.

Filter Part Number: AB.1000050
Element Replacement Part Number: AB.1000049



WARNING! Failure or improper selection or improper use of the products described in this technical data sheet can cause death, personal injury, and property damage. It is solely the responsibility of the system designer and user to select products suitable for their specific application requirements, and to ensure proper installation, operation, and maintenance of these products. It is important to analyze all aspects of the application including, but not limited to, material compatibility, product ratings, and system requirements. The products described herein, including with limitation, product features, specifications, designs, availability, and pricing, are subject to change at any time without notice.

SERIES 100 COALESCING FILTER SPECIFICATION

Maximum Rated Operating Pressure: 3600 psi (Aluminum Housing)

Operating Temperature: -40 to 250 °F

Port: 1/4" NPTF, SAE -6 by special order

Flow: Inside to Outside Element

Element: 10 micron prefilter

Coalescing Element 99.99% eff. @ .3 to .6 micron

Burst Pressure: 16,000 psi

Sump Capacity: .8 oz

Flow: 50 SCFM @ 100 psig inlet

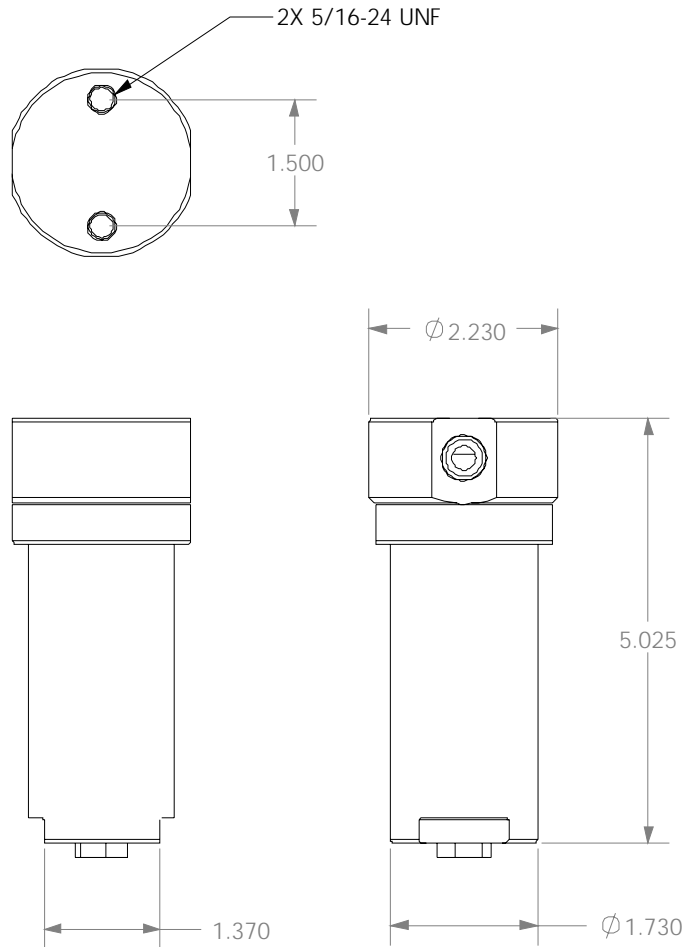

2.5 Inch Clearance Required
For Housing Removal